

**PROMULGATION OF THE NEW YORK CITY BUILDING
CODE REFERENCE STANDARD RS 6-1 AND RS 6-1A IN
RELATION TO PHOTOLUMINESCENT EXIT PATH
MARKINGS**

PURSUANT TO Chapter 26 of the New York City Charter and Sections 27-131.1 and 27-383(b) of the Administrative Code of the City of New York, and in accordance with the requirements of IRCNY §37-01(e), this proposed reference standard was previously published in the City Record on April 8, 2005 and a public hearing was held on May 2, 2005 pursuant to 1 RCNY § 37-01(f). The Department of Buildings hereby adopts New York City Building Code Reference Standard RS 6-1 and 6-1A relating to photoluminescent exit path markings.

Date: May 31, 2005
New York, New York



Patricia J. Lancaster, FAIA
Commissioner

This promulgation will be available on the Department of Building's website at NYC.gov/buildings.



Reference Standard 6-1

Photoluminescent exit path markings

as required by Local Law 26 of 2004, New York City Building Code § 27-383(b)

Introduction

This standard is intended to provide minimum requirements for photoluminescent exit path markings that will aid in evacuation from buildings in the event of failure of both the power and back-up power to the lighting and illuminated exit signs. Photoluminescent material is charged by exposure to light and will emit luminance after the activating light source is unavailable. The markings covered by this standard are not designed to provide enough light to illuminate a dark egress path, but rather will provide luminescent signs and outlines of the egress path, stairs, handrails, and obstacles, so that occupants can discern these egress path elements in dark conditions. The markings are generally required to be located at a low location in case of smoke and to be readily seen, such as in a crowd situation. They are in addition to, and not as a substitute for, any other signage required under the Building Code, such as electrically illuminated exit signs with electrical back-up power required under § 27-383(a).

This standard covers: 1) the technical specifications for minimum performance of the materials; 2) the minimum requirements for placement of the signs and markings; 3) administrative filings to certify compliance; and 4) maintenance requirements.

1.0 Technical specifications for minimum performance

- 1.1 Mandatory certifications.** All photoluminescent products covered by this standard shall be independently tested to certify compliance with the following characteristics in accordance with Reference Standard RS 6-1A:
- 1.1.1 Brightness Rating (“BR”): Minimum BR of 30-7-5, being the laboratory measurement of luminance at 10, 60, and 90 minutes, respectively
 - 1.1.2 Washability
 - 1.1.3 Toxicity
 - 1.1.4 Radioactivity
 - 1.1.5 Flame spread
- 1.2 Additional certification.** For manufacturers seeking to represent their photoluminescent products in New York City as UV resistant (resistant to UV degradation and weather), such products shall be independently tested to certify compliance with Reference Standard RS 6-1A for UV degradation. Only products meeting this characteristic shall be installed in locations exposed to unfiltered sunlight or exterior weather conditions. UV-approved products may also be used in other locations where materials with proven long-term stability are desired by the owner.
- 1.3 Approval.** Only those products approved by the Department of Buildings' Material and Equipment Acceptance Division ("MEA") shall be installed.
- 1.4 Labeling.** All approved materials shall be labeled and identified with the model number as well as with “MEA # _____ BR: _____” in a minimum of 6 point type with at least one such identification on each piece of material installed. However, labeling is not required for pieces of material less than 1 foot in length that are placed in immediate proximity of an identical model that is labeled. Those products certified for UV degradation shall be labeled with "UV" (e.g.: MEA 892-05-M BR: 39-8-6 UV). Products may include supplemental identifying information such as the manufacture’s name, trade name, or “NYC”.

Note: A Brightness Rating of 30-7-5 means that the brightness (luminance) will be 30.0 mcd/m² (millicandelas per square meter) at 10 minutes, 7.0 mcd/m² at 60 minutes, and 5.0 mcd/m² at 90 minutes, under test conditions.

2.0 Minimum requirements for placement

- 2.1 Markings on 1) doors opening to "exits" or "exit passageways"; 2) doors opening to "corridors" where such "corridors" act as required "exit passageways" connecting two "vertical exits", and 3) doors serving as "horizontal exits".¹** All such doors, other than intermediate or final exit doors, shall be marked in compliance with 2.1. Intermediate and final exit doors shall comply with 2.2.9.
- 2.1.1 Door signs.** Doors shall be marked with a photoluminescent door sign designed in compliance with 2.3.1. The top of the signs shall be no higher than 18 inches (457 mm) above the finished floor. Signs shall be installed either on the door itself, or on the wall surface directly adjacent to the door, or both:
- 2.1.1.1 Door-mounted option (fig. 1).**
The vertical centerline of the sign shall be centered with the door, or shall be in that half of the door, either the right or left, that contains the latch. In case of double-doors, both doors shall be marked and the signs shall be centered with the doors. For door-mounted signs, arrows may be omitted.

¹ As such terms are defined in the Building Code of the City of New York

2.1.1.2 Wall-mounted option (fig. 2).

Signs shall be mounted on the wall surface directly adjacent to the latch-side of the door, as close as practicable to the door such that in no case shall there be more than 6" (152 mm) from the door to the edge of the sign. In case of double-doors, signs shall be placed on the wall surface directly adjacent to the hinge-sides of both doors. Where the wall surface directly adjacent to the latch side is too narrow to accommodate the sign, the sign may be placed on the adjacent perpendicular wall. For wall-mounted signs, arrows are mandatory.

EXCEPTION – Existing buildings: For buildings constructed pursuant to plans approved prior to July 1, 2006, the top of the signs may be as high as 26 inches (660 mm) above the finish floor where necessary because of molding, baseboards, or similar features.

2.2 Markings within "vertical exits," horizontal extensions in "vertical exits," "horizontal exits," "supplemental vertical exits," and "exit passageways"²

EXCEPTION: Such markings are not required in "street level lobbies", "exterior stairs", or exterior balconies.³

2.2.1 Steps (fig. 3). The entire horizontal leading edge of each step shall be marked with a solid and continuous stripe of photoluminescent material. The dimensions, distances and locations shall be consistent and uniform throughout the same exit.

2.2.1.1 Width. The width of the stripes, measured horizontally shall be:

Maximum: 2" (51 mm)

Minimum: 1" (25 mm).

2.2.1.2 Length. The stripes shall extend for the full length of the step..

2.2.1.3 Placement. The leading edge of the stripe shall be:

Maximum: ½" (13 mm) from the leading edge of the step

Minimum: 0" from the leading edge of the step.

2.2.1.4 Overlap. The stripe shall not overlap the leading edge of the step by more than ½" (13 mm) down the vertical face of the step.

EXCEPTION – Existing buildings. For buildings constructed pursuant to plans approved prior to July 1, 2006, in lieu of marking the full horizontal leading edge as per 2.2.1, one of the following marking options may be complied with:

1. Step markings (fig. 3). The entire horizontal leading edge of each step shall be marked with a solid and continuous stripe of photoluminescent material. The dimensions, distances and locations shall be consistent and uniform throughout the same exit.

1.1 Width. The width of the stripes, measured horizontally shall be:

Maximum: 2" (51 mm)

Minimum: 1" (25 mm).

1.2 Length. The stripes shall extend to a within 2" (51 mm) of both the sides of the steps.

1.3 Placement. The leading edge of the stripe shall be:

Maximum: 1" (25 mm) from the leading edge of the step

Minimum: 0" from the leading edge of the step; or

1.4 Overlap. The stripe shall not overlap the leading edge of the step by more than ½" (13 mm) down the vertical face of the step.

2. Side edge markings (fig. 4). Side edge markings on both horizontal sides of each step that provide returns extending along the leading edge. The dimensions, distances and locations shall be consistent and uniform throughout the same exit.

² As such terms are defined in the Building Code of the City of New York

³ As such terms are defined in the Building Code of the City of New York

Such side edge markings shall be solid and continuous stripes of photoluminescent material:

2.1 Width of side edge markings. The width of the side edge marking shall comply with 2.2.1.1.

2.2 Placement of side edge markings. The side edge markings shall be placed no further than 2" (51 mm) from both sides of steps. Such stripes shall extend to within 2¼" (57 mm) of the back of each step and to within 1" (25 mm) of the leading edge of each step.

2.3 Width of returns. The returns shall also comply with 2.2.1.1 but are not required to be the same width as the side edge markings.

2.4 Placement of returns. The returns shall extend from the side edge marking, parallel with the leading edge of the step, for a minimum distance of 2" (51 mm). Such returns shall extend to within 1" (25 mm) of the leading edge of each step.

2.5 Overlap. The side edge markings including returns shall not overlap the face of the leading edge of the step by more than ½" (13 mm) down the vertical face of the step.

2.2.2 Leading edge of landings (fig. 5). The leading edge of all landings (for example the platforms at the top of stairs) shall be marked in a consistent and uniform manner throughout the same exit. Such markings shall comprise stripes following the same requirements as for steps in 2.2.1, except that: 1) the stripe shall be the same length as and consistent with the stripes on the steps, or may extend the full length of the leading edge of the landing; and 2) the leading edge of each landing shall be marked regardless of the age of the building.

2.2.3 Handrails (fig 6). All handrails and handrail extensions shall be marked with a solid and continuous stripe of photoluminescent material. The dimensions, distances and locations shall be consistent and uniform throughout the same exit.

2.2.3.1 Width. The minimum width of the stripe shall be 1" (25 mm).

2.2.3.2 Placement. The stripe shall be placed at least on the top surface of the handrail for the entire length of any handrails including handrail extensions, and newel post caps.

2.2.3.3 Continuity. Where handrails or handrail extensions bend or turn corners, the stripe shall be as continuous as practicable with no more than a 4" (102 mm) gap without photoluminescent material permitted at such bends.

EXCEPTION – Existing buildings. For buildings constructed pursuant to plans approved prior to July 1, 2006, handrails are not required to be marked.

2.2.4 Floor perimeter demarcation lines. Floor perimeter demarcations lines are intended to outline the egress path by providing low location photoluminescent lines on both sides of the path. Stair landings and other parts of the egress path shall be provided with floor perimeter demarcation lines. The lines shall be a solid and continuous 1" to 2" (25 to 51 mm) wide stripe of photoluminescent material. The continuity of the demarcation lines may be interrupted to accommodate obstructions such as conduits, moldings, corners or bends, not to exceed 4" (102 mm). The dimensions, distances and locations shall be uniform and consistent throughout the same exit. Demarcation lines shall be located on the floor, or on the walls/vertical surface, or a combination of the two, as per the following:

2.2.4.1 Floor-mounted option (fig. 7). Perimeter demarcation lines may be located on the floor, and shall be placed as close as practicable to the wall, and shall extend to within 2" (51 mm) of the markings on the leading edge of landings. Where an obstruction (such as a standpipe) is located within the egress path, the demarcation line may, at the option of the owner, extend across the floor

so that the obstruction is outside of the outlined area (see fig. 8). Demarcation lines on floors shall continue across the floor in front of all doors, except in front of those doors marked with door frame markings in accordance with 2.2.9.3 (see figs. 13, 14).

2.2.4.2 Wall-mounted option (fig. 9). Perimeter demarcation lines may be located on the wall, placed with the bottom edge no more than 4" (102 mm) above the finished floor. At the top or bottom of stairs, demarcation lines shall drop vertically to the floor within 2" (51 mm) of the step or landing edge. Demarcation lines on walls shall transition vertically to the floor and then extend across the floor where a line on the floor is the only practical method of outlining the path, for instance where obstructions or dead ends are to be outside of the outlined egress areas. Demarcation lines on walls shall continue across the face of all doors, or may transition to the floor and extend across the floor in front of such doors (see fig. 10), except in front of those doors marked with door frame markings in accordance with 2.2.9.3.

EXCEPTIONS. Perimeter demarcation lines are not required:

1. on the sides of steps; and
2. where an area is selected not to be outlined because it is not part of the egress path, for example an obstruction or dead end.

2.2.5 Obstacles. Obstacles at or below for 6'-6" (1981 mm) in height and projecting more than 4" (102 mm) into the egress path shall be outlined with markings no less than 1" (25 mm) in width comprised of a pattern of alternating equal bands, of photoluminescent material and black, with the alternating bands no more than 2" thick and angled at 45 degrees. Examples of such obstacles include standpipes, hose cabinets, wall projections, and restricted height areas (see fig. 8).

2.2.6 Directional signage upon entering an exit (fig. 11). Photoluminescent directional signs designed in compliance with 2.3.1 shall be placed in the stairwell or exit at every entrance thereto such that they are visible upon opening the door into the stairwell or exit (i.e., the opened door shall not obscure the sign). Such directional sign shall include an arrow indicating the direction of travel. The signs shall be located such that their top edge is within 18" (457 mm) above the finished floor.

EXCEPTION – Existing buildings. Buildings constructed pursuant to plans approved prior to July 1, 2006 are exempt from the requirements of 2.2.6. However, this exception shall not apply to below grade stories.

2.2.7 Directional signage at transfer levels and where egress direction is not clear (fig. 11). Photoluminescent directional signs designed in compliance with 2.3.1 and installed at heights indicated in 2.2.6 shall be placed on the wall: 1) at transfer levels; and 2) wherever egress direction is not clear. These directional signs shall include arrows indicating the direction of travel. Examples of placement include: at turns along horizontal extensions; at transitions from vertical to horizontal direction; at a "T" intersection; etc.

2.2.8 "Not An Exit" sign (fig. 12). Photoluminescent signs shall be placed on doors along the egress path that lead to dead ends (mechanical rooms, storage closets, etc.) Such signs shall contain sans serif lettering at least 1" (25 mm) high reading "NOT AN EXIT".

EXCEPTION – Existing buildings. Buildings constructed pursuant to plans approved prior to July 1, 2006 are exempt from this requirement.

2.2.9 Intermediate exit doors and final exit doors. For the purposes of this section and elsewhere in this standard, the following terms shall have the meanings set forth herein:

Intermediate exit door (fig. 13). When traveling in the egress direction, doors that lead from a vertical exit, horizontal extension in a vertical exit, horizontal exit, supplemental vertical exit, or exit passageway, but do not lead directly to the exterior or to a street level lobby are intermediate exit doors.

Final exit door (fig. 14). Doors leading directly to the exterior or a street level lobby are final exit doors.

2.2.9.1 Door signs. A photoluminescent wall-mounted door sign complying with 2.1.1.2 shall be mounted on the wall adjacent to all intermediate and final exit doors. At the final exit door, such sign shall contain supplemental directional text in sans serif letters one-half as high as the word EXIT. Examples of such texts are “FINAL EXIT”, or “EXIT THROUGH LOBBY” or “EXIT TO STREET”, or “EXIT TO CHAMBERS STREET”, etc. (see fig. 15).

2.2.9.2 Door Hardware markings. Door hardware of all intermediate and final exit doors shall be marked with no less than 16 in² (406 mm²) of photoluminescent material. This marking shall be located behind, immediately adjacent to, or on the door handle and/or escutcheon. Where a panic bar is installed, such material shall be no less than 1” (25 mm) wide for the entire length of the actuating bar or touchpad. All hardware markings covered by 2.2.9.2 may include ANSI Z535.1 safety green graphics such as arrows indicating door handle turning directions, E001 or E002 emergency egress symbols as per ISO 7010, the word “EXIT”, the word “PUSH”, and similar egress-related symbols provided the minimum 16 in² (406 mm²) of photoluminescent material is maintained.

2.2.9.3 Door frame markings. The top and sides of the door frame of all intermediate and final exit doors shall be marked with a solid and continuous 1” to 2” (25 mm to 51 mm) wide stripe of photoluminescent material. Gaps are permitted in the continuity of door frame markings where a line is fitted into a corner or bend, but shall be as small as practicable and in no case greater than 1” (25 mm).. Where the door molding does not provide enough flat surface on which to locate the stripe, the stripes may be located on the wall surrounding the frame. The dimensions, distances and locations of the required markings shall be consistent and uniform on all doors on the route to the exterior of the building.

2.3 General standards.

2.3.1 Design of door and directional signs. Unless otherwise specified, all photoluminescent door signs and directional signs referenced herein (see figs. 11, 15, 16, 17):

1. may be either positive or negative image;
2. shall be made with the non-photoluminescent portions of the signs in safety green as per ANSI Z535.1-2002, *American National Standard for Safety Color Code*;
3. shall include three components:
 - 3.1 the word EXIT printed in sans serif letters at least 4” high (102 mm) with strokes no less than ½” (13 mm);
 - 3.2 an emergency exit symbol at least 4” high (102 mm), complying with E001 or E002 as per ISO 7010 (2003-10-01), *Graphical Symbols—Safety Colours and Safety Signs—Safety Signs Used in Workplaces and Public Areas*; and
 - 3.3 an arrow at least 2 ¾” (70 mm) high, complying with E005 or E006 as per ISO 7010.

Exceptions:

1. Arrows are not mandatory on door-mounted door signs required by 2.1.1.1.
2. The word EXIT is not mandatory on directional signs required by 2.2.6 and 2.2.7.

3. Additional descriptive text is permitted, provided such words are in sans serif letters and, where the word EXIT or emergency exit symbol is required on such sign, such descriptive text is no more than one-half as high as any the work EXIT or the emergency exit symbol.

2.3.2 Solid and continuous. For the purposes of this standard, solid and continuous means without gaps or interruption, except as required for the control of expansion and contraction. A series of dashes, chevrons, dots, or other similar patterns is not solid and continuous. Nonetheless, photoluminescent materials shall be considered solid and continuous if they occasionally contain the following safety green (ANSI Z535.1) symbols or text: 1) the word EXIT, 2) egress symbol E001 or E002 as per ISO 7010; 3) direction arrows E005 or E006 as per ISO 7010, or other text or symbols as approved by the Commissioner.

2.3.3 Consistent and uniform. Where markings are required to be consistent and uniform throughout the same exit, those portions of an exit in which the egress travel direction is downward may be treated differently from those portions of the same exit in which the egress travel is upward.

2.3.4 Figures. The figures annexed are intended only for illustration, and where there is a conflict between the figures and the text, the text shall govern.

2.4 Good faith prior installations. The Commissioner may accept variations to the required dimensions, distances, returns (for side edge markings), locations, and MEA labeling for buildings where: 1) photoluminescent materials were installed prior to January 1, 2005; 2) such installations meet the intent of this standard. Applications for acceptance shall indicate all deviations from this standard. The commissioner shall require documentation that the photoluminescent materials installed achieve the equivalent brightness ratings as stated in 1.1.1 as well proof showing that the installation was completed prior to January 1, 2005. The commissioner may require installation of additional photoluminescent signs or markings in order to conform to the intent of this standard. Any such acceptance by the commissioner shall be annexed to the affidavit or report filed with the Department of Buildings pursuant to 3.3, and a copy of such report or affidavit including attachments shall be available on the premises for inspection by the Department of Buildings and Fire Department.

2.5 Installation of additional signs and markings. Where photoluminescent signs or markings are installed in locations where they are not required by 2.1 and 2.2, such signs and markings shall be MEA-approved in accordance with 1.0 (technical specifications for minimum performance). Examples of such other signs could include floor numbering signs, elevator landing signs, elevator bank indicator signs, reentry signs, etc. Where door hardware or door frame markings in accordance with 2.2.9.2 or 2.2.9.3 are provided at reentry doors, the reentry signs required by the building code shall be photoluminescent and MEA-approved in accordance with 1.0.

2.6 Other occupancies. Where photoluminescent signs or markings are installed in the exit path in other than Class E high rise buildings, such signs or markings shall comply with this standard.

3.0 Administrative filings to certify compliance

3.1 Existing buildings; Affidavit. Owners of existing buildings shall submit an affidavit of completion certifying compliance with 27-383(b) and RS 6-1, on or before July 1, 2006 for occupied buildings, or prior to issuance of a Certificate of Occupancy for new buildings under construction. In lieu of such affidavit, the owner may submit a report by an architect or engineer complying with 3.2. Such affidavit shall comply with the following:

- 3.1.1 **Inspection.** In such affidavit the owner shall certify that all components have been visually inspected, both with the normal lighting turned on, and with the normal and emergency lighting turned off.
- 3.1.2 **Product identification.** In such affidavit the owner shall identify the manufacturer and MEA approval number of each product installed, along with the manufacturer's product literature. The affidavit shall describe which particular products were installed in each part of the building.
- 3.1.3 **Paints.** Where *in situ* painting was utilized, the owner shall certify that he or she has inspected the installation and that the specified paint was utilized in accordance with the MEA-approved methods of application.

3.2 New buildings; Report. Owners of buildings filed pursuant to plans approved on or after July 1, 2006 shall submit a report of completion by an architect or engineer certifying compliance with 27-383(b) and RS 6-1, prior to issuance of a certificate of occupancy. Such report shall comply with the following:

- 3.2.1 **Inspection.** Such report shall be submitted under controlled inspection as per Building Code § 27-132. The report shall certify that all components have been visually inspected, both with the normal lighting turned on and with the normal and emergency lighting turned off.
- 3.2.2 **Product identification.** Such report shall identify the manufacturer and MEA approval number of each product installed along with the manufacturer's product literature. The report shall describe which particular products were installed in which parts of the building.
- 3.2.3 **Paints.** Where *in situ* painting was utilized, the architect or engineer shall certify that he or she has inspected the installation and that the specified paint was utilized in accordance with the MEA-approved methods of application.

3.3 Submission of Affidavit or Report. Such affidavit or report shall be filed in duplicate with the Department of Buildings' Local Law Enforcement Unit for buildings constructed pursuant to plans approved prior to July 1, 2006, and with the respective Borough Office for new buildings. A third copy of the accepted affidavit or report shall be kept and maintained on the premises for inspection by the Department of Buildings and Fire Department. Failure to have such affidavit or report available for inspection shall constitute a violation of the code.

3.4 Fire protection plans. When construction of a new building or alteration of an existing building requires that a new or amended fire protection plan be filed in accordance with section 27-228, compliance with the photoluminescent sign and marking requirements of section 27-383(b) and RS 6-1 shall be indicated in such new or amended fire protection plan.

4.0 Maintenance program. Owners shall keep the required photoluminescent signs and markings in good repair. At a minimum, owners shall, every 12 months, perform a visual inspection of the signs and marking with the normal lighting turned on. Signs and markings that are missing, damaged, loose, or that show signs of wear or missing MEA labels shall be noted and promptly repaired. The log of such inspections, including the results and any corrective measures taken, shall be kept and maintained on the premises for inspection by the Department of Buildings and Fire Department. The log shall contain the date of inspection and the printed name and signature of the person performing the inspection. Deviations from any of the requirements of this standard shall be a violation of the code.

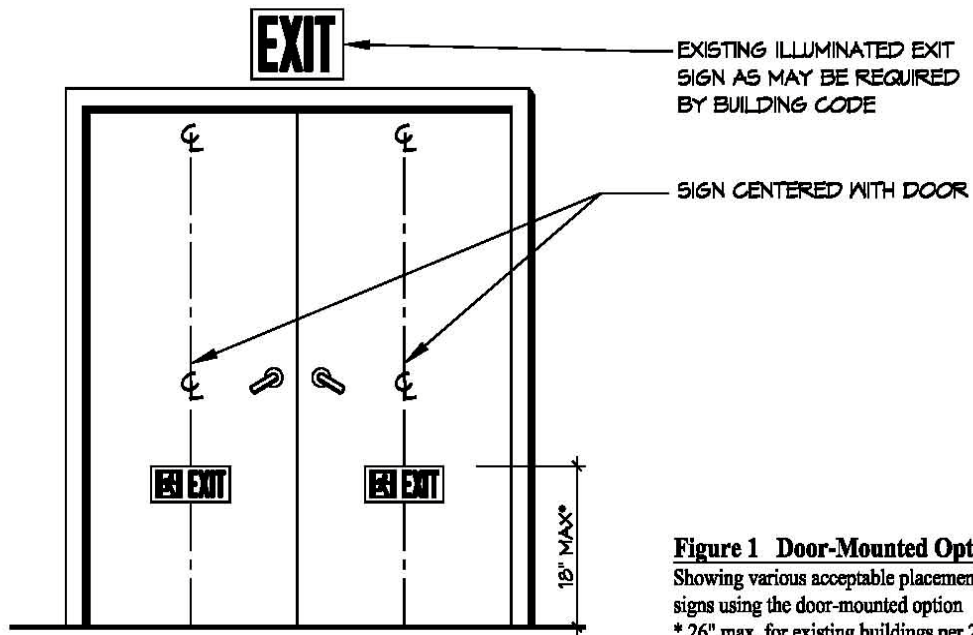
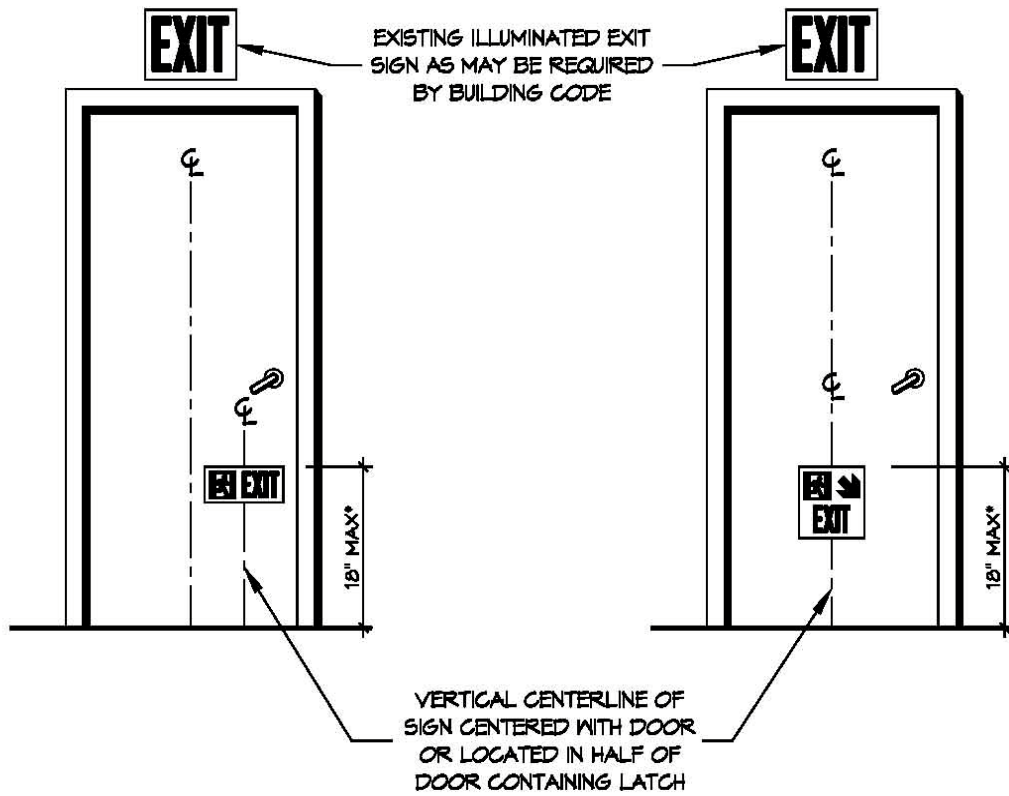

Figure 1 Door-Mounted Option (2.1.1.1)

Showing various acceptable placements for door signs using the door-mounted option

* 26" max. for existing buildings per 2.1.1

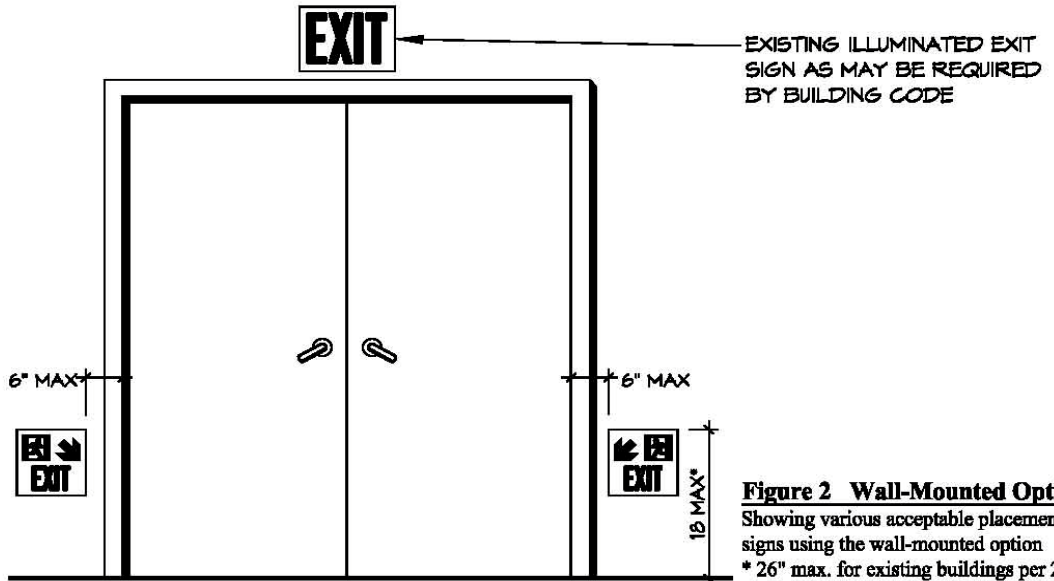
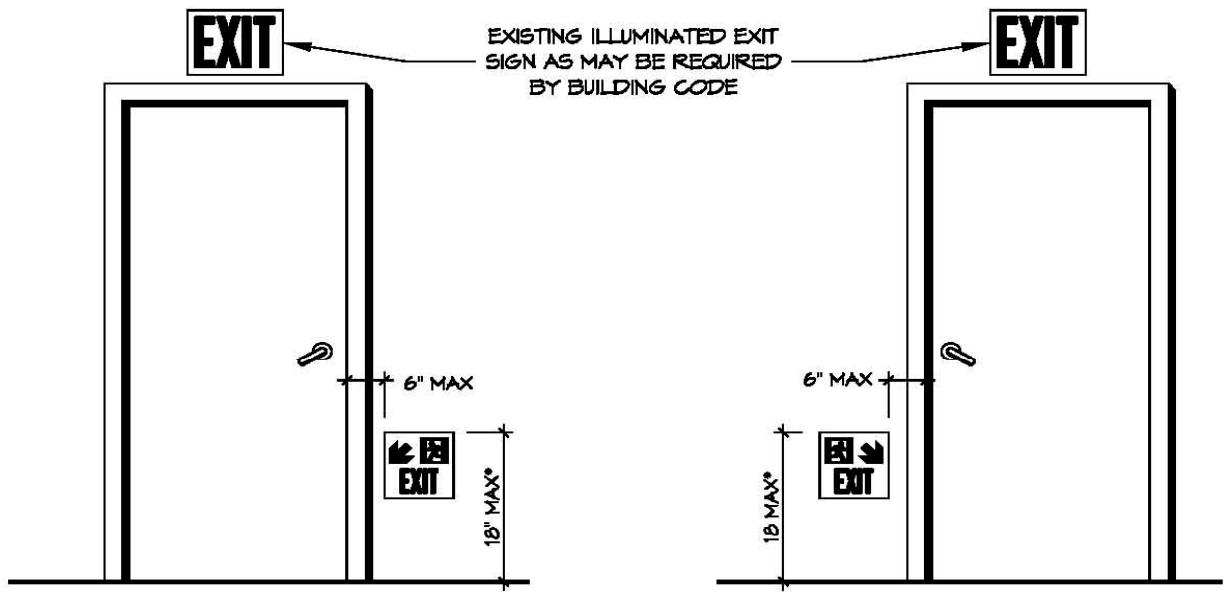

Figure 2 Wall-Mounted Option (2.1.1.2)
 Showing various acceptable placements for door signs using the wall-mounted option
 * 26" max. for existing buildings per 2.1.1

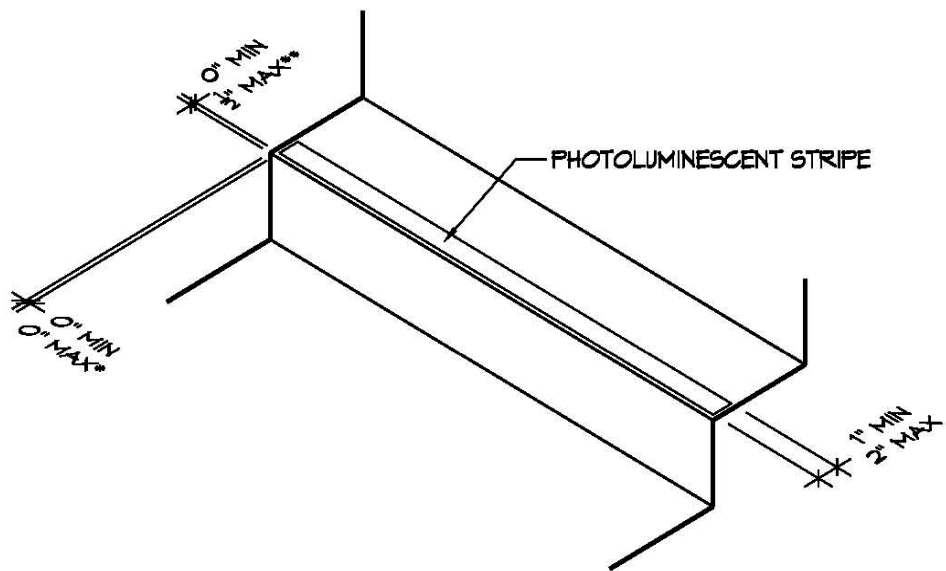

Figure 3 Horizontal Leading Edge of Step (2.2.1)

* 2" max. for existing buildings
 ** 1" max. for existing buildings

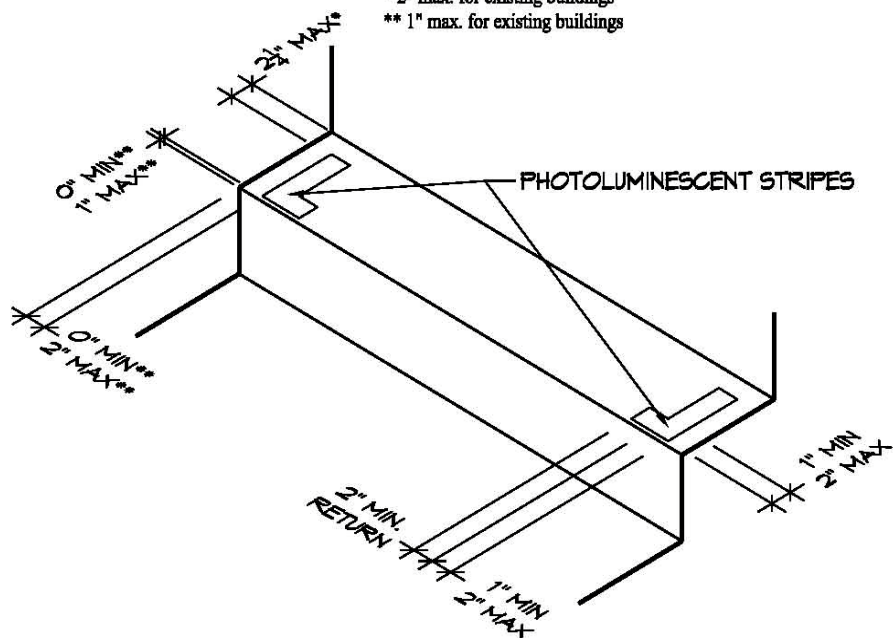

Figure 4 Alternate for Existing Buildings (2.2.1)

* Minor variations in consistency and uniformity through same exit permitted.
 ** Consistency and uniformity required.

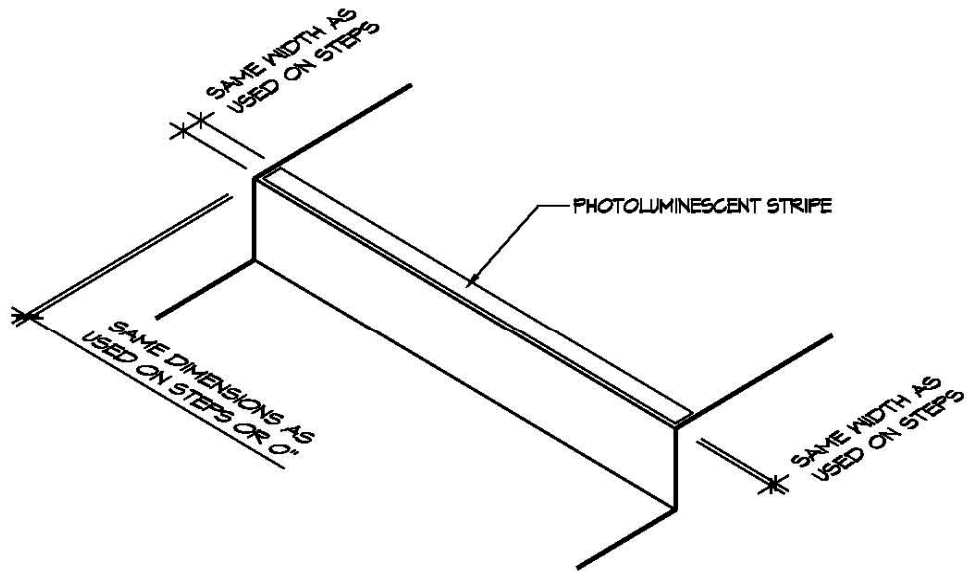

Figure 5 Leading Edge of Landings (2.2.2)
Does not show perimeter demarcation lines.

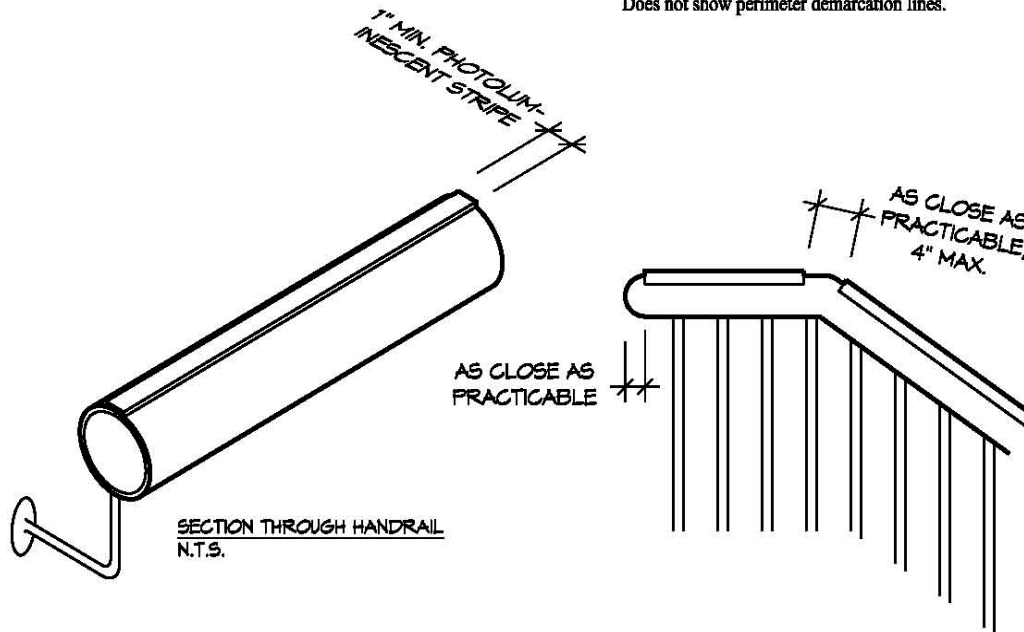

Figure 6 Handrails (2.2.3)

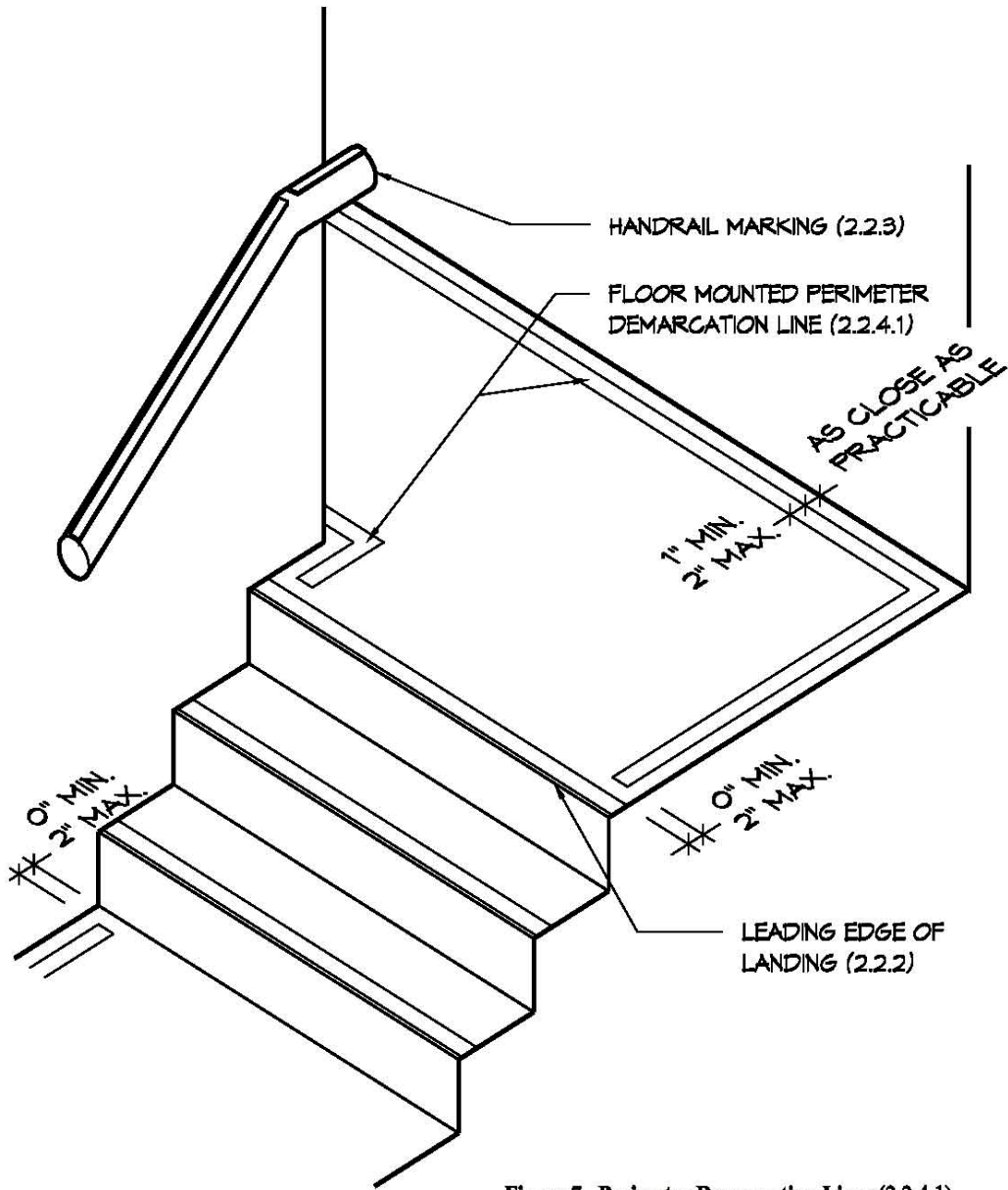

Figure 7 Perimeter Demarcation Lines (2.2.4.1)
 Showing floor-mounted option.

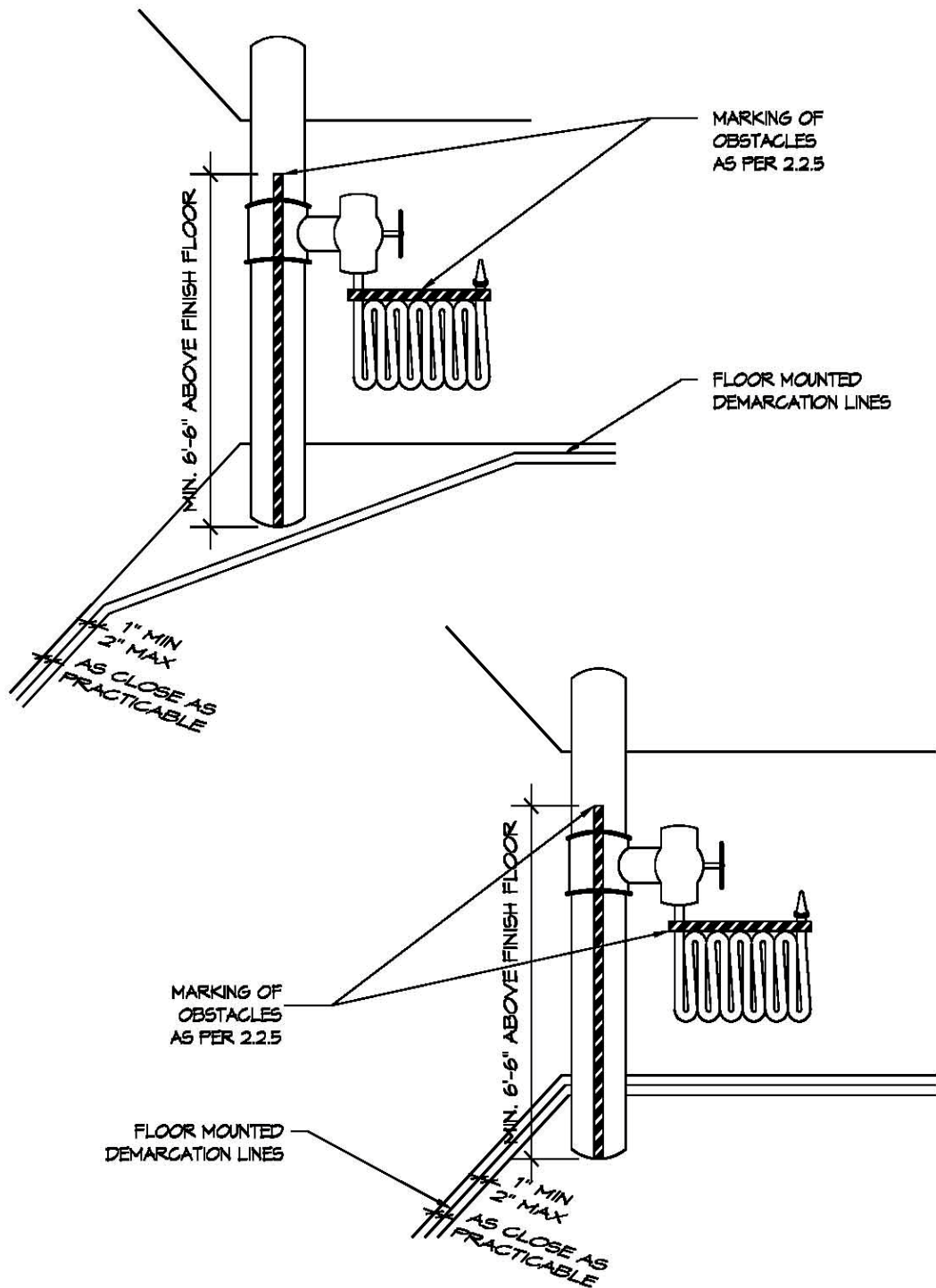

Figure 8 Perimeter Demarcation Lines (2.2.4.1)
 Showing two options at obstacles for floor-mounted demarcation lines.

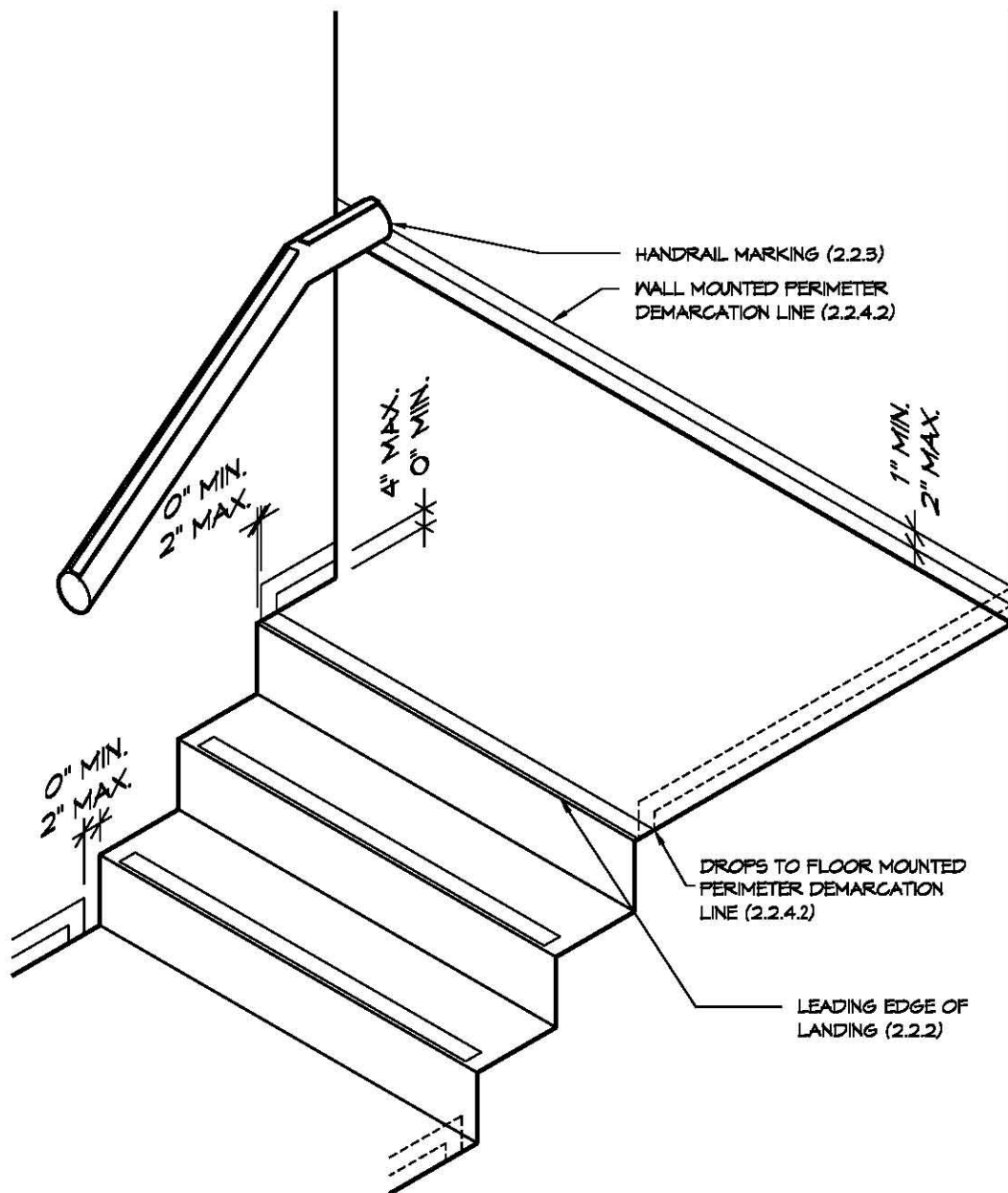

Figure 9 Perimeter Demarcation Lines (2.2.4.2)
 Showing wall-mounted option at vertical drop to floor-mounted line.

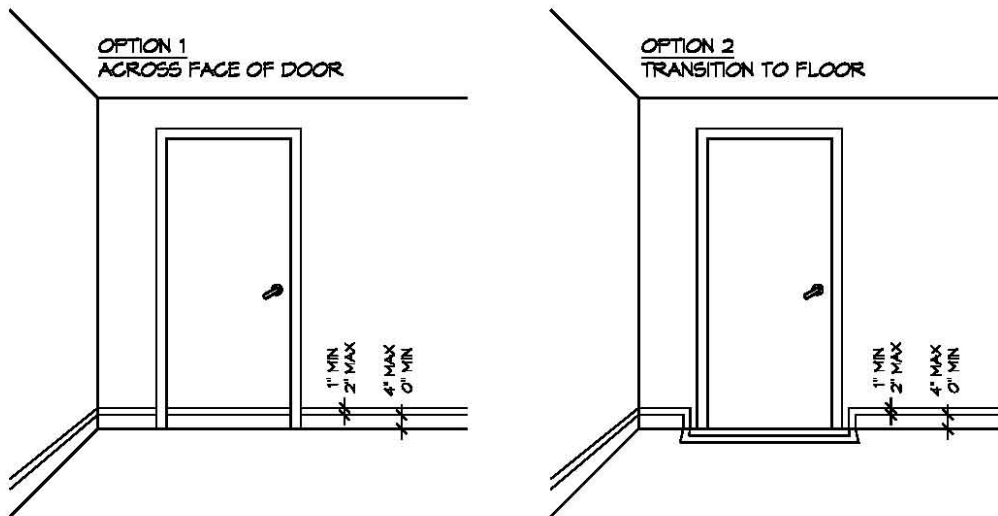

Figure 10 Perimeter Demarcation Lines (2.2.4.2)
 Showing wall-mounted option at doors that are not provided with door frame marking.

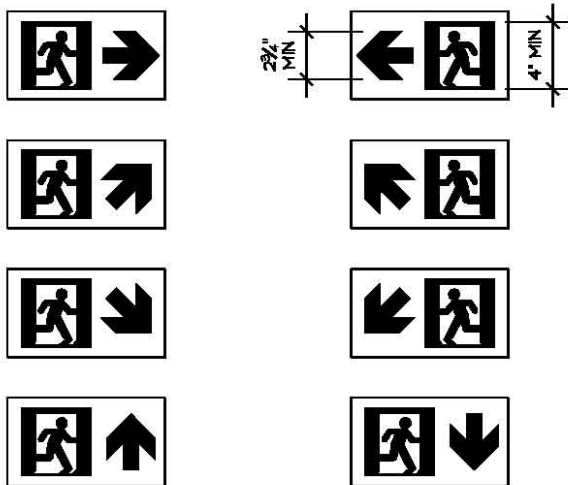

Figure 11 Directional Signage (2.2.6 and 2.2.7)

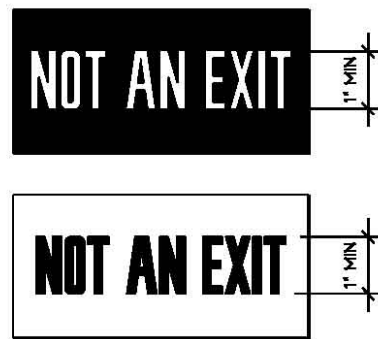
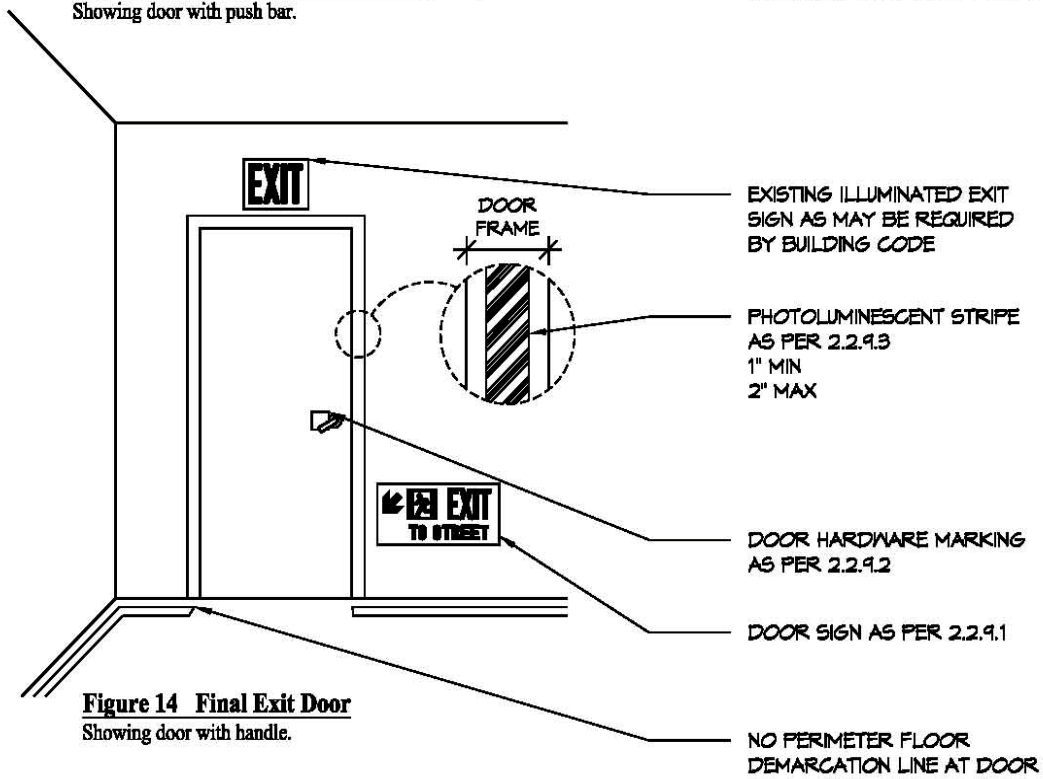
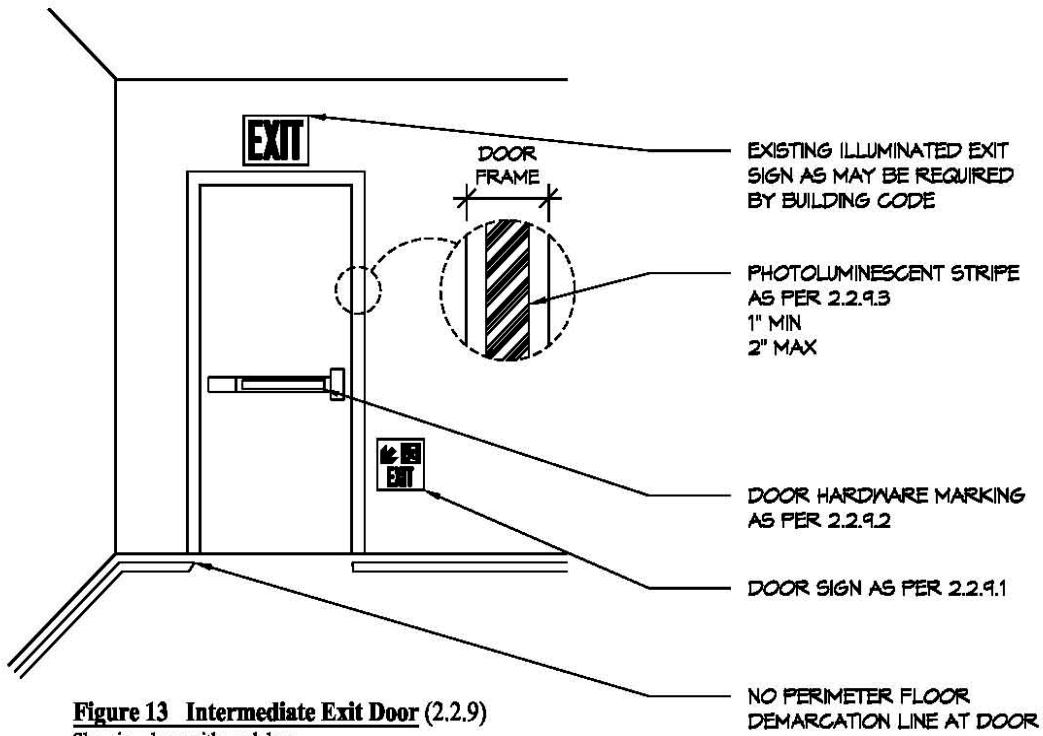

Figure 12 (2.2.8)



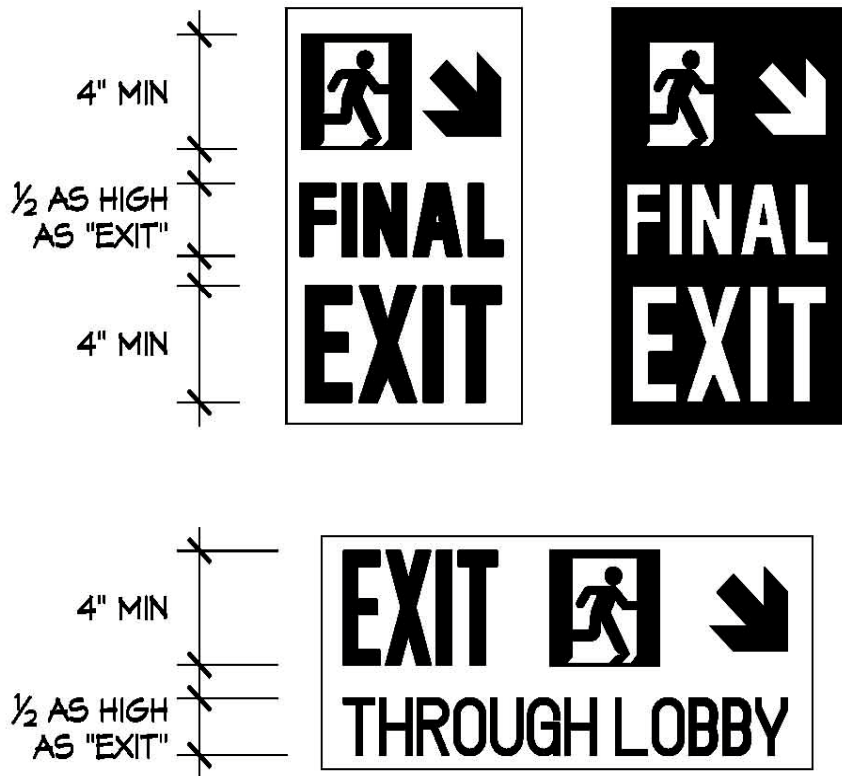

Figure 15 Final Exit Door Signs (2.2.9)
 Showing various acceptable door signs for final exit doors

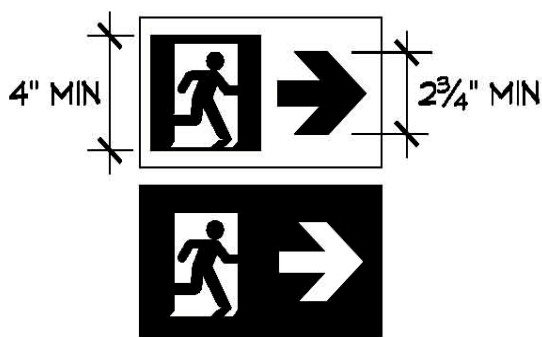

Figure 16 (2.2.6; 2.2.7; 2.3.1)
 Showing positive and negative options for directional signs

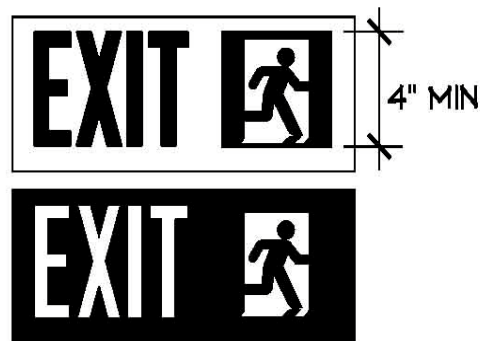

Figure 17 (2.2.2.1; 2.3.1)
 Showing positive and negative options for door-mounted door signs.

EXPLANATORY MATERIAL

The following are additional technical considerations for Reference Standard RS 6-1 and do not constitute a portion of the mandatory requirements.

A. Activating Illumination.

The products approved for use under Reference Standard 6-1 are tested in a laboratory with a fluorescent activating light source of 2 footcandles as measured on the surface of the test specimen. The measurement of 2 footcandles was derived from the minimum lighting levels as measured on the floor in exits as required by the New York City Building Code for buildings constructed after December 1, 1968. The Department of Buildings recognizes that many buildings are voluntarily providing more than 2 footcandles, and that many buildings erected before 1968 may properly be providing less. Additionally, some existing buildings are illuminated with incandescent lamps, which might not efficiently charge certain photoluminescent materials.

Reference Standard 6-1 does not permit the use of lower-performing photoluminescent products for brightly-lit environments, nor does it mandate the use of higher-performing photoluminescent products for grandfathered lighting environments. Therefore, prior to choosing a product, owners are encouraged to conduct a survey of existing lighting conditions to ensure adequate performance of the photoluminescent materials selected for the particular installation.

Reference Standard 6-1 relies on the current requirement of the New York City Building Code that continuous illumination be provided at all periods of building occupancy in corridors and exits⁴. Over the years, on a case-by-case basis, some buildings have been approved for the installation of motion-sensor activating switches allowing dark exit stairs, with the determination made that the resulting installation was equivalent to what was then required under the code. However, such determinations were made prior to the requirement of photoluminescent materials; motion-sensor devices that reduce continuous illumination to a level below the required 2 footcandles are no longer acceptable in exits where photoluminescent materials are required.

B. Dissimilar Luminance Levels Within Same Environment

It is neither necessary nor possible to require that photoluminescent products in the same environment emit identical luminance levels; many factors, including the distance to the activating light source, the angle of incidence and shadows, will result in different luminance levels for identical photoluminescent products placed in the same stairway. Variations in actual luminance are expected in the same environment. However, grossly dissimilar brightness ratings within the same environment should be avoided.

C. Contrasting Colors

Photoluminescent material are effective in completely dark conditions, and, conversely, are usually visible in normal lighting conditions. However, in dim or semi-lit conditions, such as when batteries for an emergency light are running low or when a stair is dark but a door is open to a lighted area, the photoluminescent materials forming the outlines of steps, landing, demarcation lines, and handrails might become hard to discern. Photoluminescent materials installed adjacent to a contrasting, dark color ameliorate this effect.

D. Abrasion Resistance

Reference Standard 6-1 does not mandate minimum standards for abrasion resistance. For products that are to be applied to walking surfaces, it is recommended that owners consider 1) the amount of traffic in the stairs by building occupants, and 2) the products' durability and resistance to abrasion. For instance, certain thin films and paints may be sufficient where the stairs are alarmed and only used in emergencies. However, where the occupants use the stairs on a daily basis, more durable products should be considered. Ultimately, the building owner is responsible for maintaining the photoluminescent materials in accordance with Reference Standard 6-1, Section 4.0.

⁴ As such terms are defined in the Building Code of the City of New York

E. Adhesives.

Reference Standard 6-1 does not specify the adhesives to be used. The choice of adhesive should be carefully considered for the longevity of the installation, particularly if the surface to which the product to be applied is porous, uneven, or subject to temperature or humidity variation. At a minimum owners should follow the manufacturers' instructions.

F. Slip-resistance.

Reference Standard 6-1 does not specify minimum slip-resistance requirements for photoluminescent products installed on walking surfaces. Whether or not a particular building's egress path is subject to any slip-resistance requirements may depend on the original date of construction. Any photoluminescent materials installed should be as slip-resistant as the minimum standard that is applicable to the building in which they are being installed. A stripe of photoluminescent material that is not slip-resistant may, depending on the design of the stair nosing product, be compensated for by the inclusion of an adjacent, slip-resistant strip.

G. Wall-mounted floor perimeter markings at doors.

In deciding whether to continue a wall-mounted demarcation line across a door or to transition to the floor (2.2.4.2), consideration should be given to how the door is used or secured so as to avoid the possibility that the demarcation line on the door, if left open, might lead evacuees into a non-egress space or area.



Reference Standard RS 6-1A

Additional Standards as Required by Reference Standard RS 6-1 for Photoluminescent exit path markings

Specimens to be tested shall be finished products as they would be sold to purchasers. Each distinct product material shall be separately tested and receive its respective test results for its respective Materials, Equipment and Acceptance (MEA) Division approval number. However, variation in the size of the product and differences in the text or arrow directions, etc., shall not constitute a distinct product material, but shall constitute a different model number—provided that product literature describing with pictorial representations of all such model numbers associated with the test specimens is submitted to MEA.

Thin gauge films and paints shall be tested when applied to a rigid cement board ¼" thick. In the case of paints, such painted test specimens shall be submitted along with the description of the procedures used to produce the test specimens (such as surface preparation, primer coats, number of photoluminescent coats, encapsulant coat if applicable, maximum/minimum temperature or humidity during painting if applicable, etc.). Such description shall be included in the laboratory's test report; and such description shall be included in the MEA resolution as the mandatory labeling on the paint cans as instructions to purchasers.

1.0 Brightness Rating

ISO 17398:2004, Safety Colours and Safety Signs—Classification, Performance and Durability of Safety Signs, Clause 7.11. Three specimens shall be tested (separately for each distinct product material). Thin gauge films and paints shall be tested when applied to a rigid cement board ¼" thick. The testing shall be in accordance with ISO 17398, clause 7.11, with the following modifications:

- 1.1 Clause 7.11.5 – Excitation Light Conditions. The test established in Clause 7.11.5.1. for classification of photoluminescent materials in accordance with Clause 5.5 is not required. The test in Clause 7.11.5.2 is required, however subclauses a), b), and c) are replaced with the following excitation standard: "Excitation of the phosphorescent test specimens shall be by a 4000K to 4500 K fluorescent light providing a mean illuminance of 2 footcandles (21.6 lux) on the surface of the test specimen. The excitation duration shall be 2 hours."

- 1.2 Clause 7.11.6.1 – Luminance Instrumentation. This Clause 7.11.6.1 describes two luminance instrumentation options. For this Reference Standard 6-1A, the contact luminance meter option shall be limited only to test specimens that are both smooth and flat.
- 1.3 Clause 7.11.6.4.2 – Luminance recordings for classification purposes. This Clause 7.11.6.4.2 is not required.
- 1.4 Clause 7.11.6.4.3 – Luminance recordings for product description purposes. The luminance performance shall be based on the mean values of the three test specimens measured at 10 minutes, the mean values of the three test specimens measured at 60 minutes, and the mean values of the three test specimens measured at 90 minutes. The resulting luminance performances shall constitute a "brightness rating", which shall be indicated in the test report. The minimum brightness rating shall be 30.0 mcd/m² at 10 minutes, 7.0 mcd/m² at 60 minutes, and 5.0 mcd/m² at 90 minutes. For example, a product that minimally meets the luminance levels would have a brightness rating of 30-7-5.

2.0 Washability

ASTM D 4828-1994 (2003), Standard Test Methods for Practical Washability of Organic Coatings.

- 2.1 Three specimens (of each distinct product material) shall be tested for each soil/staining medium in accordance with ASTM D 4828. Thin gauge films and paints shall be tested when applied to a rigid cement board ¼" thick.
- 2.2 The laboratory shall prepare the soils and staining media that shall include: crayon, water-borne felt-tipped pen, lipstick, and a mineral-oil-bourne soilants as outlined in clause 6.2.
- 2.3 The cleaning media shall include liquid household cleansers available at supermarkets or laboratory-standardized liquid cleansers as outlined in clause 6.3.
- 2.4 After completion of the test, each specimen shall be rated at 5 or greater in accordance with clause 8.8.

3.0 Toxicity

Bombardier SMP 800-C (Rev. 4, 11/1/2000) Toxic Gas Generation Test. One test specimen (of each distinct product material) shall be tested in each of the flaming and non-flaming modes in accordance with SMP 800-C. Where the test specimen is narrower than the required 3" x 3" (76 mm x 76 mm), more than one test specimens shall be placed next to each other to provide 9 in² (229 mm²) of surface area. Thin gauge films and paints shall be tested when applied to a rigid cement board ¼" thick. The testing shall be in accordance with SMP 800-C, with the following modifications:

- 3.1 Clause 4.3 – For determining the concentration of the toxic gases in accordance with the referenced Boeing BSS 7239 specification, the Commissioner may accept a procedure that uses gas detection tubes or other procedures, in lieu of the absorptive sampling procedure, provided that the testing laboratory outlines the procedures in its report and certifies that equivalent results are obtained.
- 3.2 Clause 5.0 – In accordance with the Building Code and departmental rules, the Department of Buildings' Materials, Equipment and Acceptance Division may approve any testing laboratory it deem qualified to perform this test.

EXCEPTION: For photoluminescent products that, when installed, provide coverage exceeding the limits of interior trim, such products shall instead be tested for toxicity as interior finishes and/or interior floor coverings if and as required by Building Code § 27-348(e) and/or § 27-351. Tread nosings with a horizontal depth of 4" or less and that contain a photoluminescent stripe may be tested in accordance with RS 6-1A.

4.0 Radioactivity

ASTM D 3648-2004, Standard Practices for the Measurement of Radioactivity.

- 4.1 Three test specimens (of each distinct product material) shall be tested in accordance with ASTM D 3648. Thin gauge films and paints shall be tested when applied to a rigid cement board.

- 4.2 The activity of the test specimens shall be shown to be statistically indistinguishable from background.
- 4.3 Alpha and beta activity shall be measured on a test specimen of at least 1 in x 1 in (25.4 mm x 25.4 mm) and counted using a proportional counter for a minimum of 15 minutes.
- 4.4 Gamma activity shall be measured on the same test specimen using a gamma spectrometer counted for at least 1 hour.

5.0 Flame Spread – either one of the following two standards:

- 5.1 *ASTM E 162-2002, Standard Test Method for Surface Flammability of Materials Using a Radiant Heat Energy Source.*
 - 5.1.1 Four test specimens (of each distinct product material) shall be tested in accordance with ASTM E 162. Where the test specimen is narrower than required by the test, several pieces may be grouped together to provide the necessary surface area. Thin gauge films and paints shall be tested when applied to a rigid cement board ¼” thick.
 - 5.1.2 The specimens shall have a flame spread index (Is) not to exceed 35.
- 5.2 *ASTM D 635-2003, Standard Test Method for Rate of Burning and/or Extent and Time of Burning of Plastics in a Horizontal Position.*
 - 5.2.1 Ten test specimens shall be prepared for use in accordance with ASTM D 635.
 - 5.2.2 The test specimens shall not burn beyond the 25 mm reference mark.

EXCEPTION: For photoluminescent products that, when installed, provide coverage exceeding the limits of interior trim, such products shall instead be tested for flame spread and smoke density as interior finishes and/or interior floor coverings if and as required by Building Code § 27-348(c) and (d) and/or § 27-351. Tread nosings with a horizontal depth of 4” or less and that contain a photoluminescent stripe may be tested in accordance with RS 6-1A.

6.0 UV Degradation ("UV") (only where a "UV" rating is requested for exterior weather conditions or unfiltered sunlight applications)

ASTM G 155-2004, Standard Practice for Operating Xenon Arc Light Apparatus for Exposure of Nonmetallic Materials.

- 6.1 Three specimens (of each distinct product material) shall be tested for a period of 1000 hours in accordance with ASTM G 155. The specimens shall be subjected to Cycle 1 exposure condition noted in Table x3.1 of such standard. Thin gauge films and paints shall be tested when applied to a rigid cement board ¼” thick.
- 6.2 The testing laboratory that conducted the weathering test shall certify that none of the following surface characteristics exist when viewed under a minimum of 5x magnification: cracking, checking, crazing, or erosion.
- 6.3 After conclusion of the testing, such laboratory shall directly send the specimens to the testing laboratory that conducted the brightness rating tests in 1.0.
- 6.4 The brightness rating testing laboratory shall perform luminance tests as per 1.0 on the weathered specimens and report the results. The specimens shall indicate at least 90% of the original brightness at 10 minutes, at least 90% of the original brightness at 60 minutes, and at least 90% of the original brightness at 90 minutes, as compared to the brightness ratings prior to the weathering test.



STATEMENT OF BASIS AND PURPOSE:

The September 11th terrorist attacks and subsequent collapse of the World Trade Center (WTC) Twin Towers and building number 7 WTC were a national tragedy that had an enormous impact on New York City, more than the obvious physical damage.

Before 9/11, New York City was commonly acknowledged to have one of the most stringent building codes in the United States. The aftermath of these attacks caused us to rethink our codes in relation to high-rise building safety. The lessons learned from the tragedy had a practical application for improvements to our codes. To that end, the New York City Department of Buildings convened the World Trade Center Building Code Task Force (Task Force) to review current building design, construction and operating requirements for high rise office buildings, and to determine if modifications were needed to enhance public safety.

The Task Force brought together a broad coalition of affected groups, including experts from both the public and private sectors (government, academia and industry) and survivors of the attacks. It was this deliberate consensus building that ensured the success of the Task Force.

In February 2003, the Task Force released its findings (available at <http://nyc.gov/html/dob/pdf/wtcbctf.pdf>), recommending changes to the way that high-rise office buildings are designed and how they function during an extreme event. The Task Force focused its efforts in four main areas: structural strength, evacuation and egress, fire protection, and mechanical systems. The resulting recommendations serve public safety and are realistic and practicable. Thirteen of these recommendations were signed into law on June 24, 2004 by Local Law 26 of 2004, which amended the New York City Building Code and Fire Prevention Code.

One component of Local Law 26 of 2004 mandates the retroactive installation of photoluminescent signs and markings in high rise office buildings on or before July 1, 2006, and requires that the Commissioner of Buildings adopt a reference standard establishing the technical standards for the installation and placement of the standards on or before January 1, 2006.

This proposed Reference Standard RS 6-1 and 6-1A establish the technical standards for the installation of photoluminescent building signs in compliance with Local Law 26 of 2004.